

INSTRUCTION MANUAL

HM-10L (SIEG X2L) Mini Mill Drill - Tilting Head (240V) (X) 300mm (Y) 130mm (Z) 180mm



M150A

CONTENTS

CHAPTER 1 SPECIFICATION

- 1-1 Machine specification
- 1-2 Packing list of accessories

CHAPTER 2 MACHINE INSTALLATION

- 2-1 Fundamental locating of the machine
- 2-2 Preparation before operation

CHAPTER 3 PREVENTION AND MAINTENANCE

- 3-1 Prevention and maintenance
- 3-2 Maintenance of cutter and taper shank
- 3-3 Mechanics lubrication

CHAPTER 4 MACHINE STRUCTURE

- 4-1 External feature
- 4-2 Assembly and parts

CHAPTER 5 MECHANISM ADJUSTMENT

- 5-1 Installation and removal of taper shank
- 5-2 Travel adjustment
- 5-3 Adjust dip angle of fuselage

CHAPTER 6 OPERATION AND NOTICE FOR USE

- 6-1 Method of operation
- 6-2 Operation attention

CHAPTER 7 GENERAL SAFETY INSTRUCTION

CHAPTER 8 POWER CONNECTION & ELECTRICITY

- 8-1 Power connection/disconnection & Operation
- 8-2 Electrical circuit diagram

Some Safety Features of this Machine

- a) Purpose of this machine: This machine is designed for drilling, deep milling and face milling of small work piece with limit of size "300mm × 200mm × 200mm".
If the operator intend to use this machine beyond our design purpose, please contract the manufacturer or your dealer before operation.
- b) The following items is prohibited for this machine
- operating machine without going through of manual.
 - operating machine without professional training of drilling & milling work.
 - operation machine beyond the design purpose and limit of this machine without getting sufficient consultant about safety from manufacturer or our agent.
 - operating machine without making sure that every safety precaution is well according to this instruction.
- c) Some important safety information.
- The noise level during operation is 70~75dB(A).
 - The temperature rang suitable for the operation & storage of this machine is -20~+40 degree C.
- d) Special Warning for this machine:
- Warning! After interruption due to power failure, There exist the risk of accidentally running up. Be sure to pay attention to this risk and turn off machine as soon as machine interrupt.
 - Warning! Always wear approved eye protection during operation.
- e) Correct handling of this machine.
- The net weight of this machine is 50Kg. It would be better to handle this machine with the help of appropriate lifting tool.
 - If the operator has to handle this machine without lifting tool, be sure to make sure you can afford this weight, and handle it with care and with common sense of self-protection.

CHAPTER 1 SPECIFICATION

This is a mini vertical milling machine with multiple functions on either face mill or drill. There are various sizes and kinds of cutter currently. It's easy to purchase, that can apply different function to insure you work more accurate and more efficient as long as you change the cutter upon your demand.

1-1 Machine Specification

SPECIFICATION

Max.table travel	9" (228mm)
Max.cross slide	4" (100mm)
Max.spindle travel	8 1/2" (215mm)
Spindle Rotary Angle	-45°~+45°
Input. Power	350W
Spindle Speed	L:0~1100rpm H:0~2500rpm
Taper of hole in spindle	MT #3
Drilling Capacity	1/2" (13mm)
End Milling Capacity	1/2" (13mm)
Face Milling Capacity	1" (25mm)
Machine Weight	GW:68kg NW:50 Kg
Shipping Dimension	560mm × 500mm × 740mm(L × W × H)

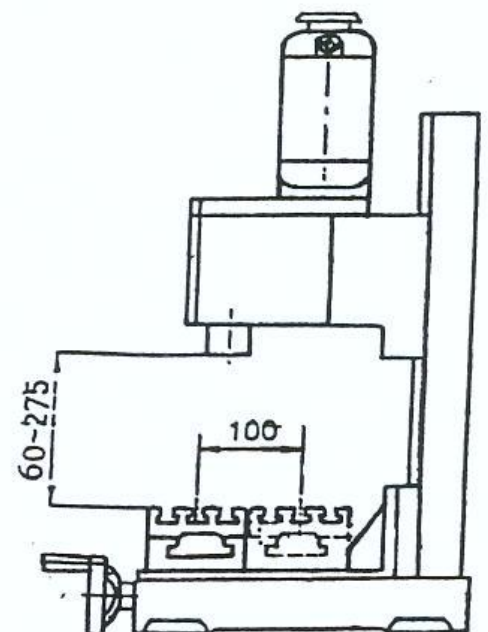
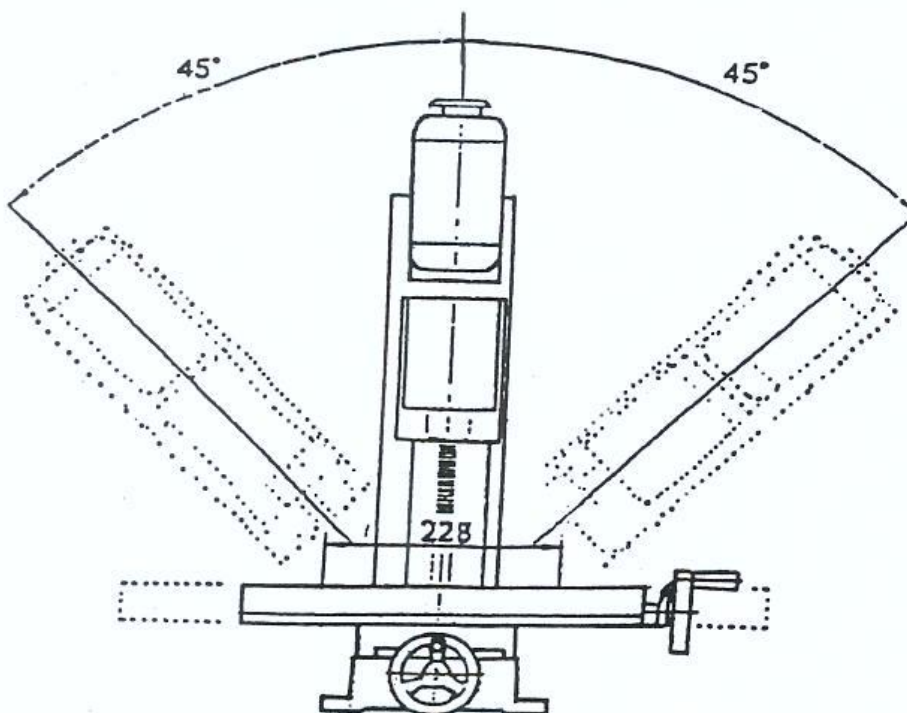

Taper Shank Specification-MT#3

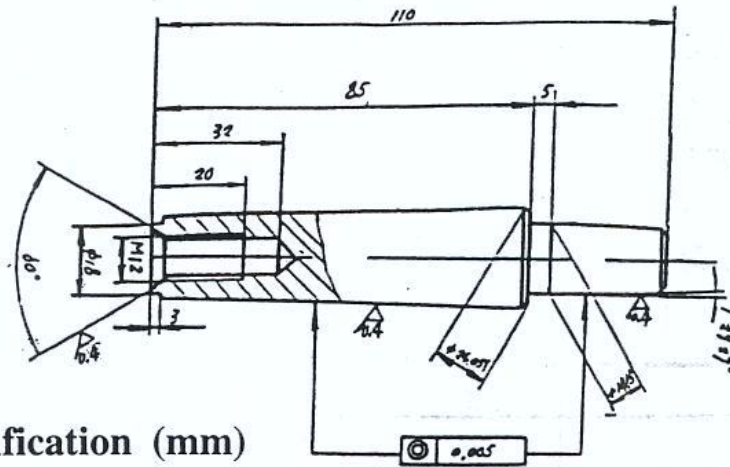

T-Slot Specification (mm)

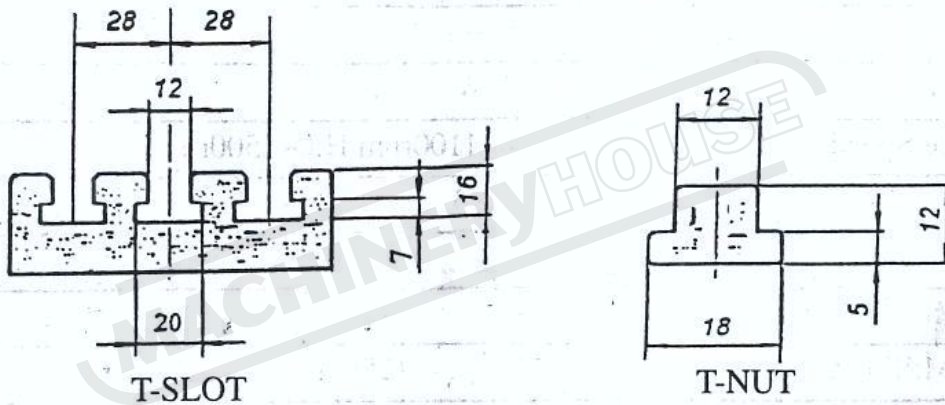

1-2 Packing list of Accessories

- 1. Big wrench S:36 1
- 2. 13mm Drill chuck & taper shank 1
- 3. Oil can 1
- 4. Fixing Pin 1
- 5. L Hex.Wrench S:3,4,5,6 4
- 6. Socket head wrench D:45-52 1
- 7. Double end wrench 8-10,14-17, 17-19 3
- 8. Drill chuck holder 1
- 9. Handle 2
- 10 T-Nut 2
- 11 Fuse 5A(110V) or 3A(230V) 1
- 12 Draw bar 1

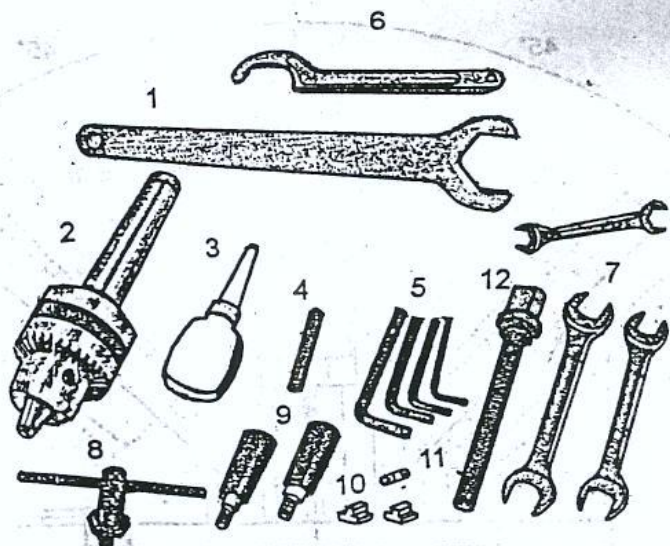

CHAPTER 2 MACHINE INSTALLATION

2-1 Fundamental Locating of The Machine

The machine should be fixed on the working table with four Hexagon bolts. Please install it to an appropriate location in order to demand the precision requirements of the machine.

The Selection of The Installing Location

- (1) The working table should have a flat surface.
- (2) Avoid the place with direct sunshine, heavy moisture and dust.

Method of Fundamental Locating

- (1) Please drill 4 locating holes on working table, the dimensions should be the same as the holes on the machine's base.

(Attention: the machine's position. You had better consider Y-axis hand wheel, because the exceeding of Y-axis hand wheel will benefit later on.)

- (2) Please adjust the machine to horizon and fix the worktable with 4 M10 bolts and nuts.

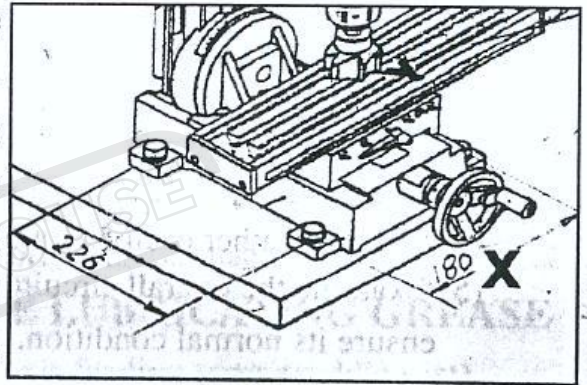

2-2 Check the Follow Items Before Switching On the Machine:

Please make sure to obey the above regulations in order to avoid injury of the operator and safety of the machine.

1. Remove all of fixtures which used for fixing the machine when you equipped the machine.
2. Check whether the power voltage is suited to the machine.
(see label in front of the machine.)
3. Remove all obstacle which are around the machine.
4. Remove anti-rust protection which were used before you fixed the machine.
5. Check the angle of the pillar and adjust the bolts to see if they are tight enough.
6. Check the chuck, chuck holder and fixing pin on spindle to make sure they are unloaded.
7. Check the High-Low speed on spindle to see if it sets on right speed.
8. Turn on the machine and check the direction of spindle rotating (clockwise).
9. Operate Longitudinal Axis (Working table), Cross Axis (Saddle seat), Vertical Axis (Fuselage) to ensure it's in normal condition,
10. During the operation, watch out while you're manipulating the machine.
If there is any unusual situation, stop operating and repair immediately.

CHAPTER 3 PREVENTION AND MAINTENANCE

3-1 Prevention And Maintenance

3-1.1 Daily Maintenance

- (1) Inspect each operating part to ensure the condition of lubrication.
- (2) To examine each component if the part is fixed and no other abnormal situations.
- (3) Please clean and remove the obstacles around the machine in order to prevent machine damage and safety of the operator.
- (4) Please keep the machine clean after daily use and lubricate the movement parting to prevent rust.
- (5) Please watch out the operation while you're manipulating the machine.

In case that there is any unusual phenomena, please stop and repair immediately.

3-1.2 Sensonal Maintenance

- (1) Please use clean cotton or soft gauze to clean each part of the machine.
- (2) Please confirm whether the motion of machine's head and fixture are smooth or loosen.
- (3) Check whether the spindle is over-swing.
- (4) Check whether each bolt and nut is loosen.
- (5) Examine the overall circuit(contact points conductor, plugs and switches...) to ensure its normal condition.

3-1.3 Seasonal Maintenance

- (1) Please perform the maintenance on each level and make record.
- (2) Please stop the machine before replacing the part or maintenance in order to avoid danger.
- (3) Maintenance and repair showed be done regularity. If any abnormal situation occurs, stop the machine and repair immediately.
- (4) If the abnormal situation is beyond the regular maintenance. Please contact our service engineer nearest to you in order to avoid further damage and safety.

3-2 Maintenance of Accessories

3-2.1 Maintenance of Cutter

- (1) Use rag while install or unload the cutter to prevent the cutter falling and cause the split of blade as well as hurt the figures.
- (2) Keep the cutter in wooden or plastic box when you don't need it. In order to maintain the sharp blade, the cutter should be kept respectively.
- (3) Pay extra attention on cutter rotating direction. Wrong rotating direction might cause sharpness and split blade and accelerate the cutter exhaustion. If it is hard to identify the blade direction in high speed revolving,

the working piece and mill it.

- (4) Sharpen the cutter as soon as it gets sharpness. Sharpness cutter is not only hard to do the milling work but also easy to cause damage on blade.

3-2.2 Attention Items For Accessories

- (1) Please keep the taper shank clean.
- (2) Please keep the taper shank and cutter in order and keep the same cutter together. Next time when you use them, you will feel more convenient.
- (3) Draw bar and chuck have their own wrenches. For your convenience, please keep the wrenches near by the machine and never operate the machine with inappropriate tools.
- (4) Please use wrench to tight the nuts and never use other tools such as steel hammer to do so.

3-3 Mechanics Lubrication

In order to ensure the precision, keep lubrication on contact face.

In accessories, there is an oil-can, use it to lubricate. Please inject some lubricant to all of contact face before operating.

The following are the item that needs to make lubrication on machine.



USE LUBRICATING OIL

- (1) Basement and saddle seat slide face.
- (2) Saddle seat and working table slide face.
- (3) Fuselage gear and connecting strut slide face.
- (4) Fuselage and spindle box slide face.

USE LUBRICATING GREASE

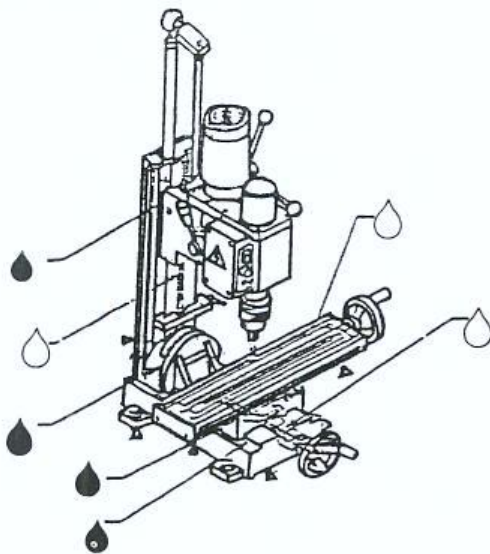
- (1) X-Axis feeding screw (saddle seat).
- (2) Y-Axis feeding screw (working table).
- (3) Z-Axis feeding gear rack (fuselage).



-  Lubricating grease
-  Lubricating oil
-  Point of lift force

After working, clean the work table and lubricate with a little lubricant to protect the worktable.

CHAPTER 4 MACHINE STRUCTURE

4-1 External Feature

- A. Motor
- B. Headstock housing & spindle
- C. Chuck
- D. Longitudinal feed hand wheel
- E. Working table
- F. Saddle
- G. Cross feed hand wheel
- H. Base
- I. Connecting strut
- J. Controller
- K. Fuselage
- L. Limit block
- M. Cushioning cylinder
- N. Fine feeding wheel

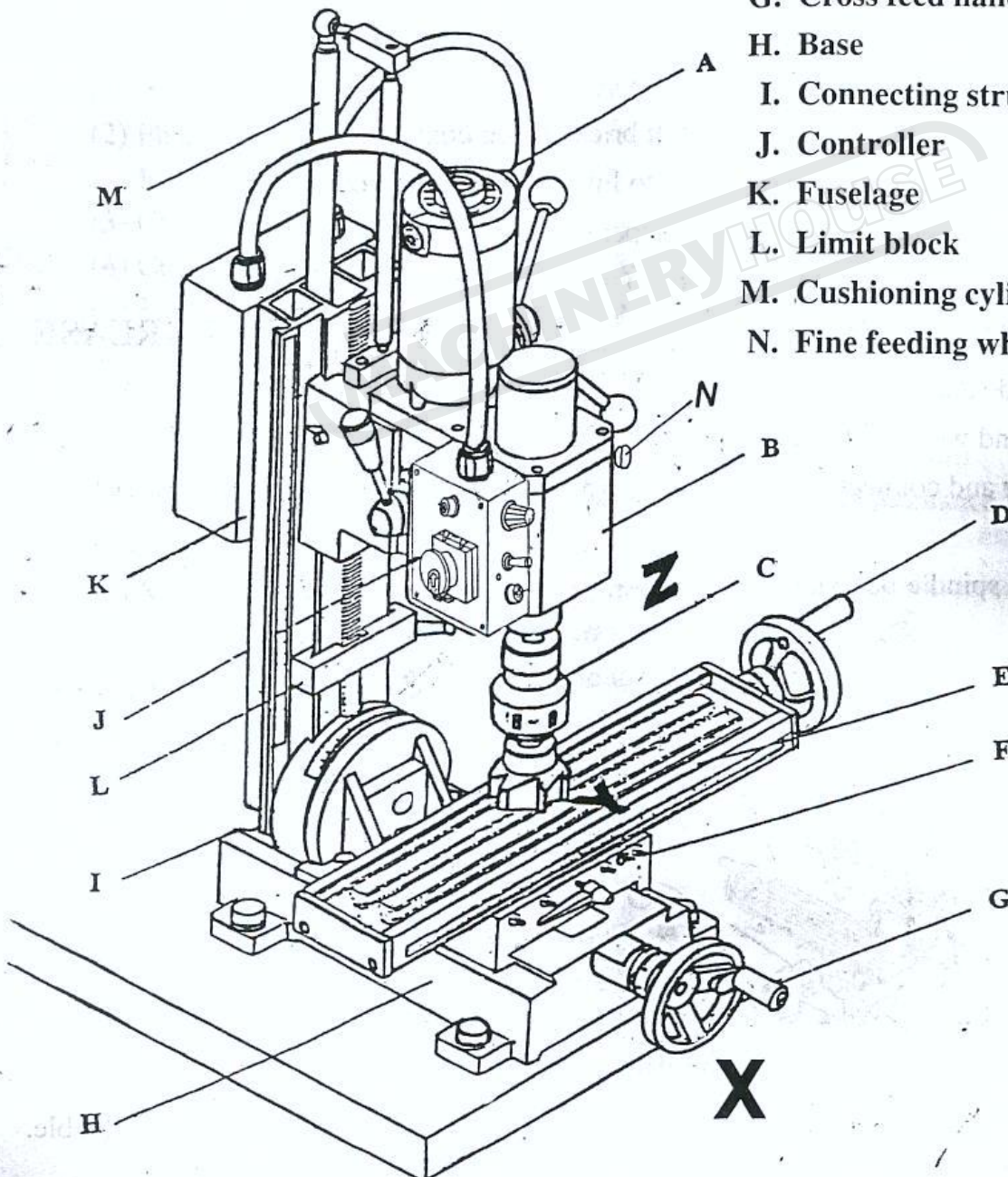

4-2 Assembly and Parts

Longitudinal (Y) Axis Cross (X) Axis

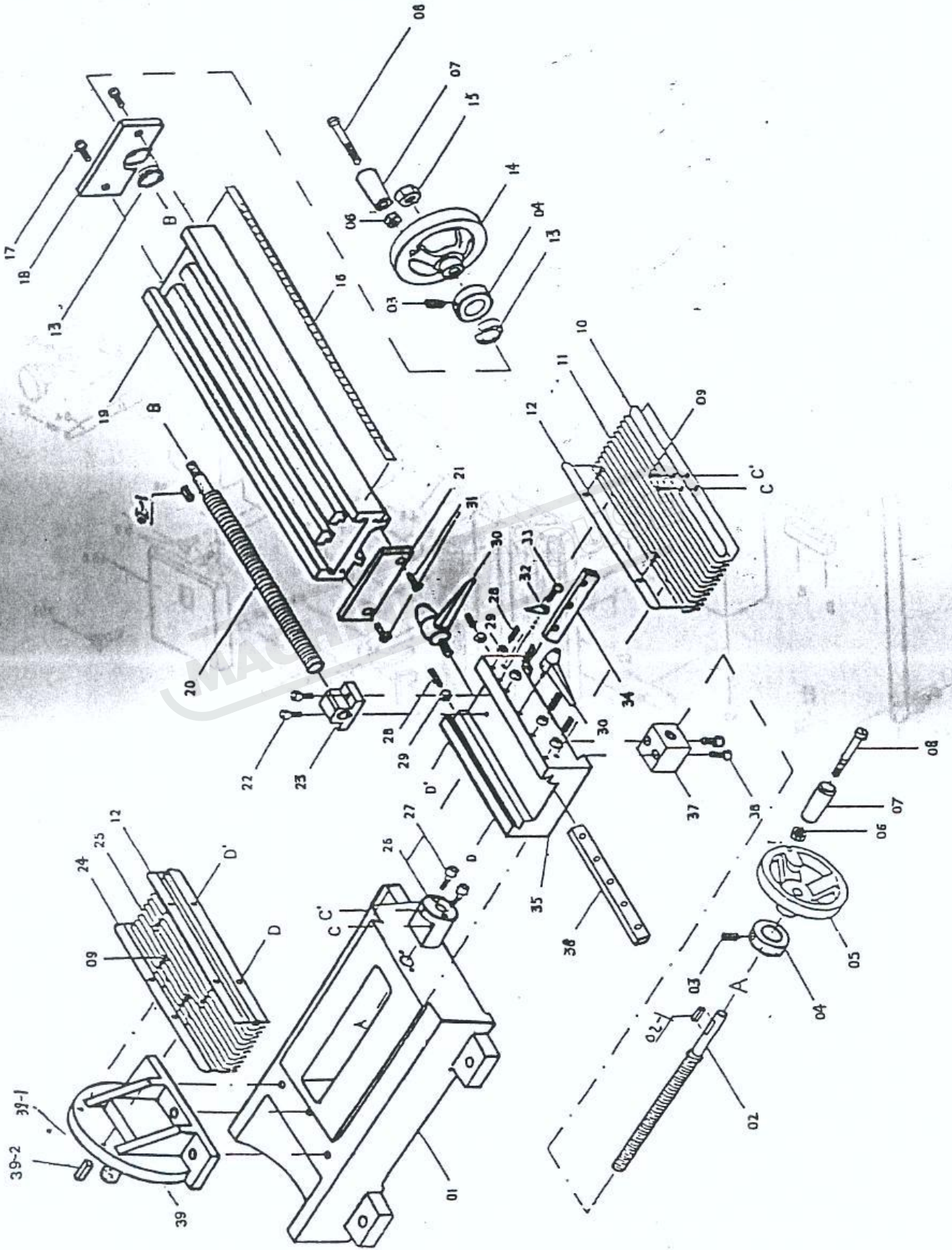

Vertical(Z)Axis

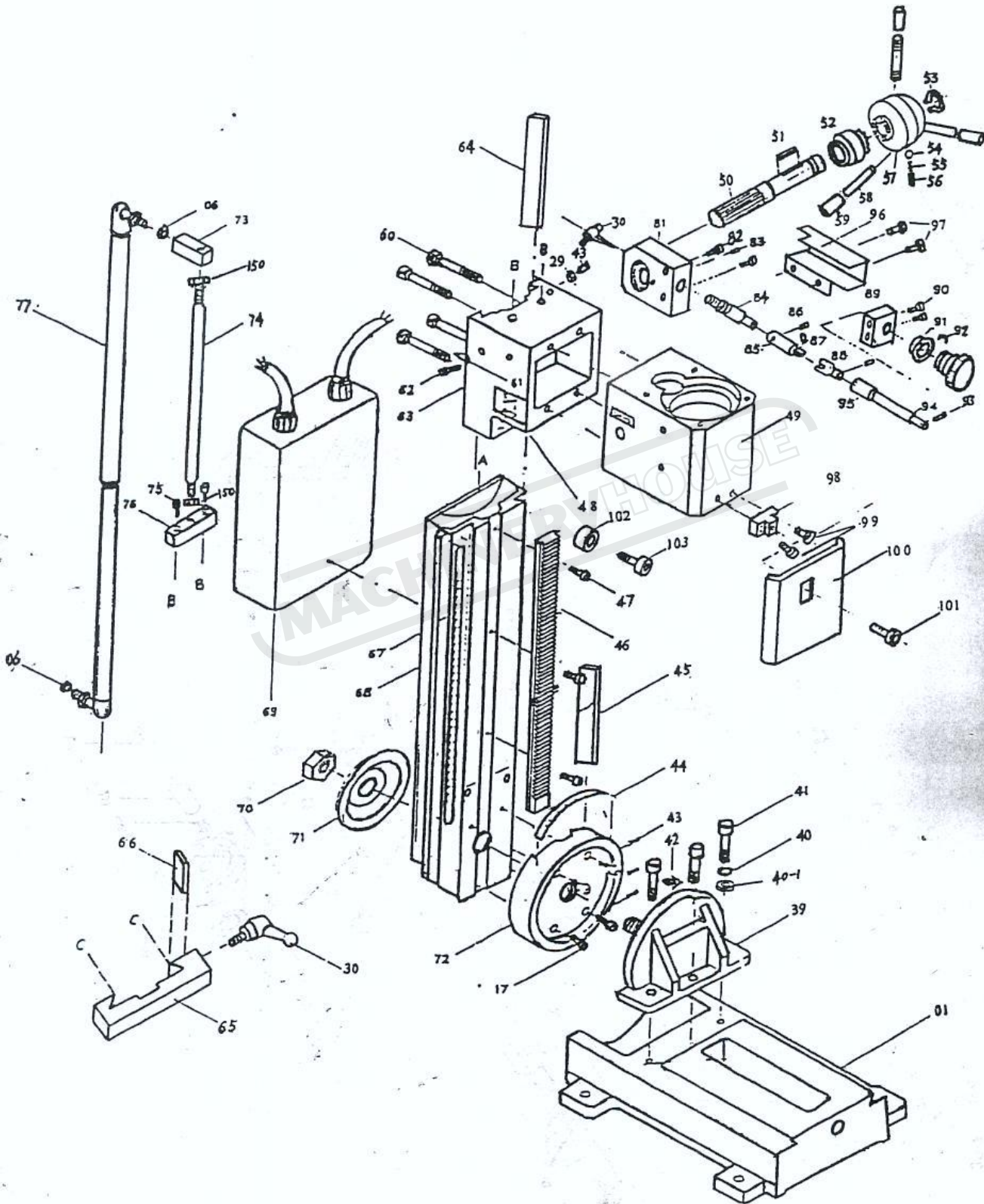

Spindle and Gear box

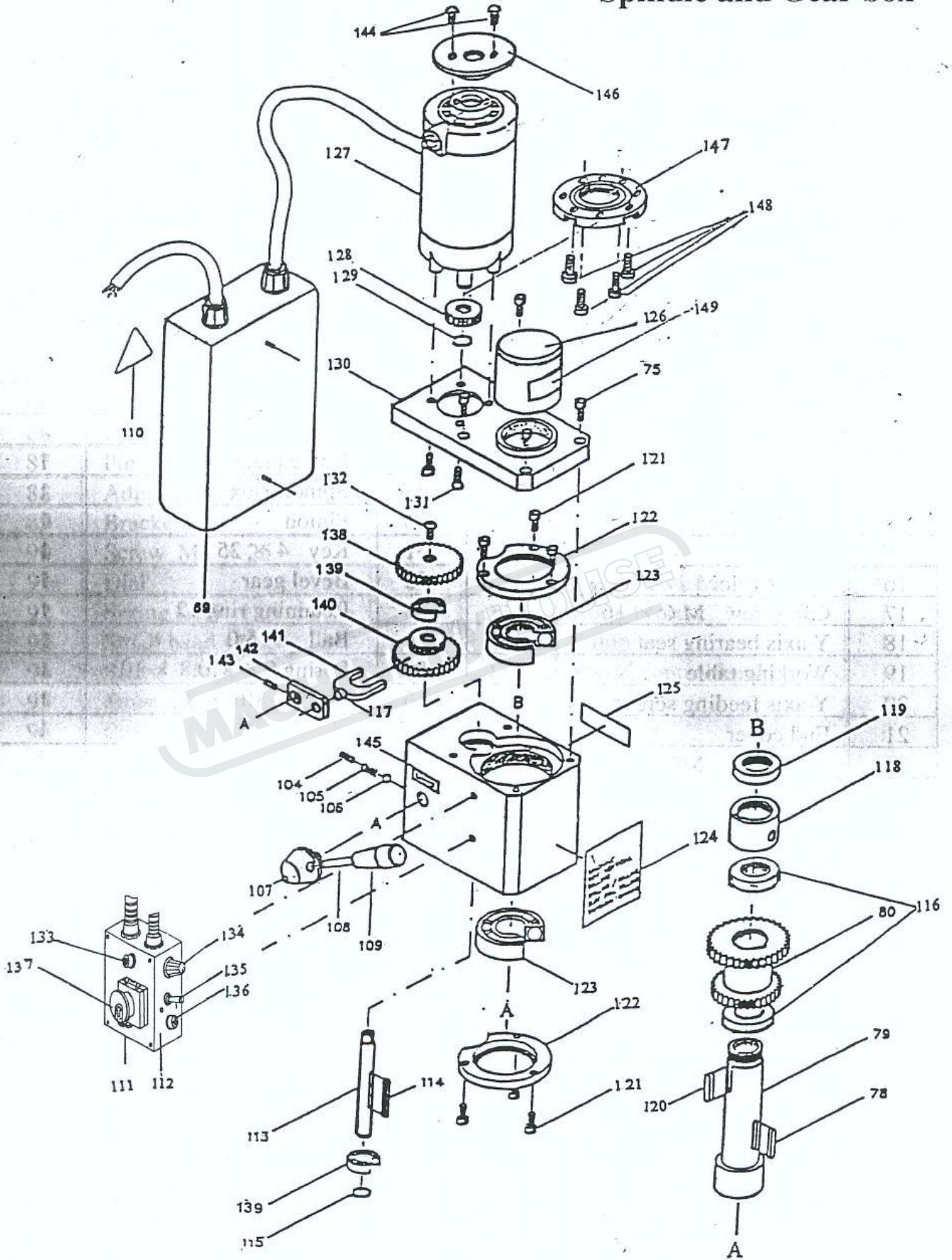

□ Parts List

Item No	Part Name	Q'ty	Item No	Part Name	Q'ty
1	Base	1	38	Cap screw M6 × 25	2
2	X-axis feeding screw	1	39	Fuselage seat	1
2-1	Key 4 × 16	2	39-1	Shaft	1
3	Spring	2	39-2	Key 8 × 12	1
4	Graduated collar	2	40-1	Washer 10	3
5	Hand wheel	1	41	Cap screw M10 × 30	3
6	Nut M8	4	42	Guide finger	2
7	Knob	2	43	Set screw M6 × 22	7
8	Screw M8 × 55	2	44	Ruler	1
9	Cap screw M6 × 8	8	45	Wedge	1
10	Holding plate (1)	1	46	Gear rack	1
11	Dust guard cover	1	47	Cap screw M6 × 16	4
12	Holding plate (2)	2	48	Name plate	1
13	Ball bearing 8200	2	49	Spindle box	1
14	Hand wheel	1	50	Pinion	1
15	Nut M8	8	51	Key 4 × 25	1
16	Y-axis ruler	1	52	Bevel gear	1
17	Cap screw M6 × 16	6	53	Retaining ring 12	1
18	Y-axis bearing seat	1	54	Ball ∅ 5.0	1
19	Working table	1	55	Spring 0.8 × 0.8 × 10	1
20	Y-axis feeding screw	1	56	Screw M6 × 8	1
21	End cover	1	57	Handle stock	1
22	Cap screw M6 × 10	2	58	Operating lever	3
23	Y-axis screw nut	1	59	Lever cap	3
24	Holding plate (3)	1	60	Cap screw M8 × 25	4
25	Dust guard cover	1	61	Guide finger	1
26	Screw seat	1	62	Cap screw M6 × 25	1
27	Cap screw M6 × 16	2	63	Spindle box seat	1
28	Set screw M6 × 22	6	64	Wedge	1
29	Nut M6	13	65	Limit block	1
30	Handle	3	66	Wedge	1
31	Screw M6 × 10	2	67	Ruler	1
32	Guide finger	1	68	Fuselage	1
33	Screw M6 × 8	1	69	Electric box	1
34	X-axis wedge	1	70	Lock nut M24	1
35	Saddle	1	71	Big washer	1
36	Y-axis wedge	1	72	Connecting strut	1
37	X-axis screw nut	1	73	Connecting board	1

Item No	Part Name	Q'ty	Item No	Part Name	Q'ty
74	Pitman shaft	1	114	Double round head key 4 × 4 × 45	1
75	Cap screw M6 × 20	2	115	Internal ring \varnothing 12	1
76	Connecting block	1	116	Spacing ring	2
77	Cushioning cylinder	1	117	Small shaft	1
78	Key 5 × 5 × 40	1	118	Spacing ring	1
79	Spindle	1	119	Spindle nut	1
80	Transmission gear	1	120	Double round head key 5 × 5 × 30	1
81	Support block	1	121	Cap screw M5 × 8	6
82	Screw M5 × 20	2	122	Bearing cover	2
83	Pin 4 × 15	1	123	Ball bearing 80206	2
84	Worm	1	124	Name plate	1
85	Sleeve	1	125	Fine feeding label	1
86	Pin 3 × 12	1	126	Protecting cover	1
87	Pin 3 × 12	2	127	Motor	1
88	Adjustable union	1	128	Motor gear	1
89	Bracket	1	129	Intering ring 9.0	1
90	Screw M5 × 25	1	130	Motor seat	1
91	Dial	1	131	Flat screw M6 × 12	1
92	Spring steel 1.0	1	132	Round screw M5 × 8	1
93	Small hand wheel	1	133	Lamp	1
94	Screw M4 × 14	1	134	Speed control knob	1
95	Small shaft	1	135	Switch	1
96	Cover	1	136	Fuse box	1
97	Screw M4 × 6	2	137	Emergency stop switch	1
98	Support of dust cover	1	138	Gear	1
99	Screw M5 × 16	2	139	Ball bearing 80101	2
100	Dust guard	1	140	Transmission gear	1
101	Clamp bolt M6 × 12	1	141	Bar	1
102	Upper end washer	1	142	Linking board	1
103	Upper end screw M6 × 16	1	143	Set screw M5 × 8	1
104	Set screw M6 × 6	1	144	Self-tapping Screw ST 2.9 × 8	2
105	Spring 0.8 × 4.8 × 10	1	145	H/L label	1
106	Ball \varnothing 5.0	1	146	Motor cover	1
107	Handle seat	1	147	Motor connecting flange	4
108	Double head bolt M8 × 70	1	148	Screw M6 × 10	1
109	Knob	1	149	Warning label	1
110	Warning label	1		PC board	1
111	Controller	1		Potentiometer	1
112	Label on controller	1		Fuse	1
113	Shaft (1)	1	150	Nut M10	2

CHAPTER 5 MECHANISM ADJUSTMENT

5-1 Installation and Removal of Taper shank

Installation

- (1) Turn off the main power before you replace the cutter.
- (2) Pull out the protective cover(a).
- (3) Wipe the spindle sleeve and taper shank.
- (4) Put the taper shank(g) into spindle sleeve. Cutter should be matted with oil cloth to keep the safety of machine and fingers.
- (5) Insert fixing Pin(d) right on spindle sleeve.
- (6) Use #14 open end wrench(c) to tight(clockwise) spindle draw bar(b) for fixing taper shank.
- (7) Pull out the fixing pin!
- (8) Install the protective cover(a).

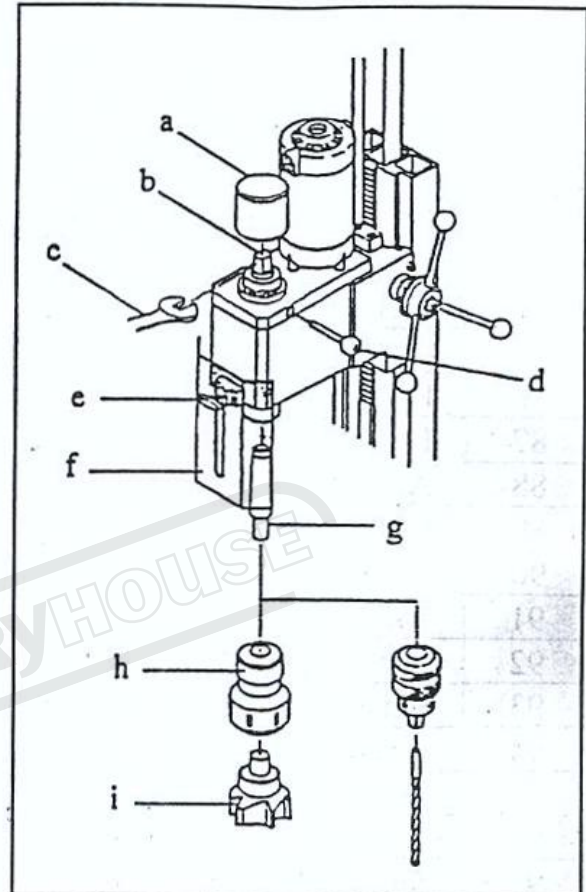

Removal

- (1) Turn off the main power before you replace the cutter.
- (2) Pull out the protective cover(a).
- (3) Insert fixing pin(d) right on spindle sleeve.
- (4) Use #14 open end wrench (c) to loose (counter clockwise) the spindle draw bar(b).
- (5) Knock the taper shank (g) gently by plastic hammer to loose it in spindle sleeve. Then take off the taper shank(g).
- (6) Cutter should be matted with oil cloth to keep the safety of machine and fingers.
- (7) Install the protective cover(a).

※ For your safety,

any adjustment on machine

should be operated

under no electricity. ※

5-2 Travel Adjustment

Using the limit block can control the traveling of spindle box.

- (1) Loosen the handle(a) beside of the limit block(b).
- (2) Adjust the limit block(b) in position.
- (3) Tighten the handle.
- (4) Travel position can refer to the ruler on the fuselage rotary.

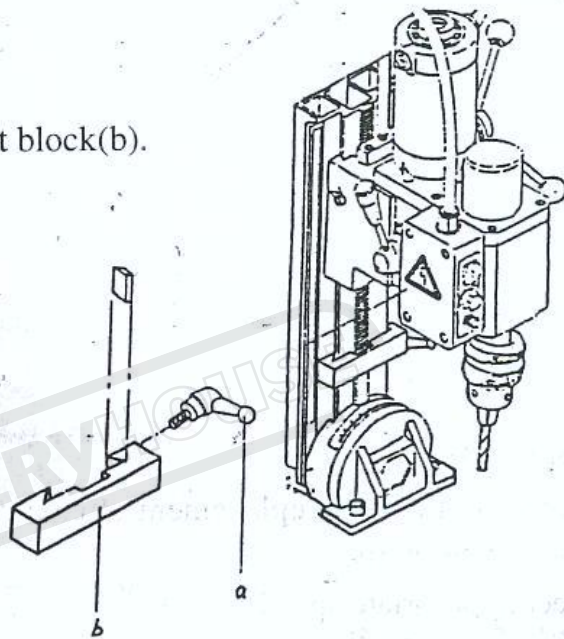

5-3 Adjust Dip Angle of Fuselage

- (1) Turn off the main power before adjustment.
- (2) Hold the fuselage by hands, avoid the fuselage falling then endanger the operator and machine.
- (3) Loosen the locked nut(a) with great wrench(b).
- (4) Adjust the fuselage dip angle as you need (Max is 45° both lefts and right).
- (5) Tighten it!

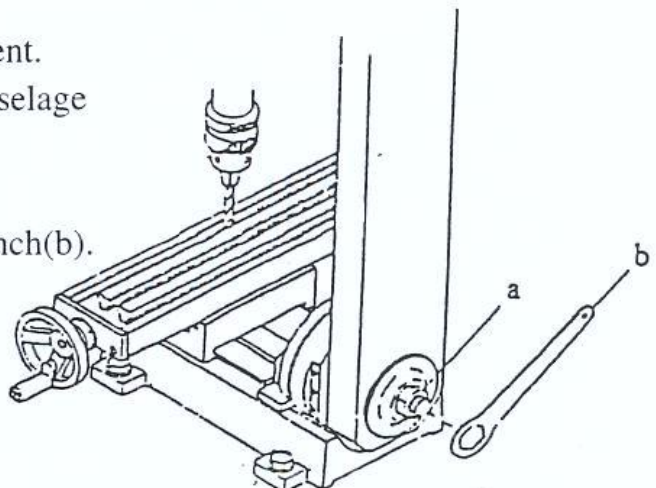

CHAPTER 6 OPERATION AND NOTICE FOR USE

6-1 Method of Operation

Drilling or Deep Milling

1. According to Chp5, replacement of chuck and tool. Install appropriate adjustment and tighten it certainly.
2. Select appropriate speed level. **[ATTENTION:When spindle is running, don't change the HIGH/LOW speed !]**
3. Use press cake or fixture set the workpiece on the working table.
4. Adjust working table (Longitudinal Axis (Y)) and Saddle seat (Cross Axis(X)) in position.
5. Loosen the limit block handle, adjust the blocks in position. Note don't let tool meet the workpiece.
6. Put Adjusting tools in order and remove all obstacles which are around the machine.
7. Turn on the main power. Adjust appropriate spindle speed and drilling or deep milling.
8. Refer the ruler on fuselage can know drilling or milling depth.
9. Finish working, turn off power and take the spindle to upper position.
10. Clean the machine.

Face Milling

1. According to Chp5, replacement of chuck and tool. Install appropriate adjustment and tighten it certainly.
2. Select appropriate speed level. **[ATTENTION:When spindle is running, don't change the HIGH/LOW speed]**
3. Use press cake or fixture set the workpiece on the working table.
4. Adjust working table (Longitudinal Axis(Y)) and Saddle seat (Cross Axis (X) in position.
5. Release limit block on fuselage, adjust the depth of cut, then fixed.
6. Arrange all tools in proper place.
7. Turn hand wheel of working table(Y-axis) and saddle seat (X-axis) to do face milling.
8. Finishing all steps, turn off power and make spindle return to upper position, release workpiece.
9. Clean the machine.

Drilling or Milling Speed

Before any operation, set the spindle to a correct speed of running.

The operating speed range for working is 0 to 2500 rpm. For most part, the correct speed may consider the size of working face and the material. Generally, you can use higher speed for softer material or small holes. Use lower speed for harder material or bigger holes.

A good rule of thumb is: Smaller hole and the softer material, use higher speed.

But don't drill too fast(above 2300 rpm) if your workpiece is wood,or you may turn it. For metal,the speed can from 0 to 2500 rpm.

6-2 Attend for Operation

Please attend the following items as you operate in order to ensure the operation safety and maintain the capacity of machine.

Inspection before turn on

- 1.Before turn on power,you must check the tool chuck and cutter tighten it certainly.
- 2.Inspect whether each machine part has loosen.
- 3.Check the rod of speed adjustment at correct position certainly.
- 4.Workpiece is fixed with press cake or fixture certainly.
- 5.Clean and remove the obstacles around the machine.

During Operation

- 1.Drinking alcohol or being worse spirited is absolutely forbidden to operate the machine.
- 2.Wearing gloves or necktie is absolutely forbidden to operate the machine.
- 3.Select and install appropriate cutter,no loosen.
- 4.The machine will shaking as follows condition:
 - a.The depth of cut is too deep.
 - b.The feeding speed is too fast.
 - c.The rotation speed is too fast.
 - d.The machine and stock plane is not fixed firmly.
 - e.The vice and workpiece is not fixed firmly.

Protection and Maintenance

- 1.Please perform the maintenance on each level and make a record.
- 2.Please turn off the power perform maintenance or projection.
- 3.Please inform our dealer to assign professional person to deal with the action beyond extent of individual maintenance and protection.

CHAPTER 7 GENERAL SAFETY INSTRUCTION

Warning! When using electric tools, basic safety precautions should always be followed to reduce the risk of fire, electric shock and personal injury, including the following. Read all these instructions before operating this product and save these instructions.

1. Keep work area clean.
 - Cluttered areas and benches invite injuries.
2. Consider work area environment.
 - Do not expose power to rain. Do not use power tools in damp or wet locations.
 - Keep work area well lit. Do not use power tools where there is risk to cause fire or explosion.
3. Guard against electric shock.
 - Avoid body contact with earthed or grounded surfaces (e.g. pipes, radiators, ranges, refrigerators.)
4. Keep children away.
 - Do not let visitors touch the tool or extension cord. All visitors should be kept away from work area.
5. Store idle tools.
 - When not in use, tools should be stored in a dry, high or locked up place, out of reach of children.
6. Do not force the tools.
 - It will do the job better and safer at the rate for which it was intended.
7. Use the right tools.
 - Do not force small tools or attachments to do the job of a heavy duty tool. Do not use tools for purposes not intended; for example, do not use circular saws to cut three limbs or logs.
8. Dress properly.
 - Do not wear loose clothing or jewelry, they can be caught in moving parts. Rubber gloves and non-skid footwear are recommended when working outdoors. Wear protecting hair covering to contain long hair.
9. Use safety glasses.
 - Also use face or dust mask if the cutting operation is dusty.
10. Connect dust extraction equipment.
 - If devices are provided for the connection of extraction and collection facilities, ensure these are connected and properly used.
11. Do not abuse the cord.
 - Never carry the tool by cord or yank it to disconnect it from the socket, keep the cord away from heat, oil and sharp edges.
12. Secure work
 - Use clamp or a vice to hold the work. It is safer than using your hand, and it frees both hands to operate the tool.

13. Do not overreach.
 - Keep proper footing and balance at all times.
14. Maintain tools with care.
 - Keep cutting tool sharp and clean for better and safer performance. Follow instructions for lubrication and changing accessories. Inspect tool cord periodically and if damaged have it repaired by an authorized serviced facility. Inspect extension cords periodically and replace, if damaged. Keep handle dry, clean and free from oil and grease.
15. Disconnect tools.
 - When not in use, before servicing and when changing accessories such as blade, bits and cutters.
16. Remove adjusting keys and wrenches.
 - Form the habit of checking to see that keys and adjusting wrenches are removed from the tool before turning it on.
17. Avoid unintentional starting.
 - Do not carry a plugged-in tool with a finger on the switch. Ensure switch is off when plugging in.
18. Use outdoor extension leads.
 - When tool is used outdoors, use only extension cords intended for outdoor use.
19. Stay alert.
 - Watch what you are doing. Use common sense. Do not operate tool when you are tired.
20. Check damaged parts.
 - Before further use of the tool, a guard or other part that is damaged should be carefully checked to determine that it will operate properly and perform its intended function. Check for alignment of moving parts, free running of moving parts, breakage of parts, mounting and any other conditions that may affect its operation. A guard or other part that is damaged should be properly repaired or replaced by an authorized service center unless otherwise indicated in this instruction manual. Have defective switches replaced by an authorized service facility. Do not use the tool if the switch does not turn it on and off.
21. Warning.
 - The use of any accessory or attachment, other than those recommended in this instruction manual, may present a risk of personal injury.
22. Have your tool repaired by a qualified person.
 - This electric tool is in accordance with the relevant safety requirements. Repairs should only be carried out by qualified persons using original spare parts, otherwise this may result in considerable danger to the user.

CHAPTER 8 POWER CONNECTION & ELECTRICITY

8-1 Power Connection/disconnection & Operation

1. The connection, disconnection, and grounding is carried out through the plug, equipped on the machine. For the safety reason, Do not change this plug into any the other type in any situation.
2. For the protection of control device, we recommend the operator to supply a fuse with current rating and the total length between fuse and connection terminal shall be according **“EXTENSION LEAD CHART”**

EXTENSION LEAD CHART

Ampere rating	3A	6A	10A	13A
Extension Cable Length	Wire Size mm ²			
7.5m	0.75	0.75	1.0	1.25
15m	0.75	0.75	1.0	1.5
22.5m	0.75	0.75	1.0	1.5
30m	0.75	0.75	1.25	1.5
45.5m	0.75	1.25	1.5	2.5

3. The exact power source is 110V or 230V ,single phase, 50/60Hz. (see label in front of the machine)
4. Make sure the Emergency Stop switch(A) (left beside the electrical box) is in **“OFF”** position before plugging in cord.
5. Disconnect tools from power source with plug before servicing and when changing accessories such as guard.

Operation

1. INITIAL START

Taking all precautions stated, set the HIGH-LOW range lever to Low. Insert the electric plug into the socket.

Put the Motor power switch(E) to “T”, then release the Emergency Stop Switch(A) by pushing down on the red knob slightly and pushing it up, as indicated by the arrow on the top of the red knob.

Switch on the machine by GENTLY turning the Variable Speed Control

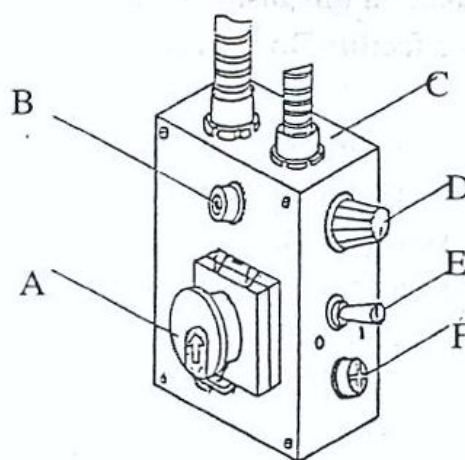

- A: Emergency stop switch B: Green lamp
 C: Electric control box D: Variable speed control knob
 E: Motor power switch F: Fuse box

knob(D),clockwise.A click will be heard as motor power is turn on,but the spindle will not rotate until the knob is turning clockwise a little further.Speed will increase progressively the further the knob is turn.Run for a total of 5 minutes during which time gradually increase spindle speed to its maximum.Run for at least 2 minutes at this speed before stopping the machine and disconnecting from the mains supply.

Check that all components are still secure and working freely and correctly.

Check also to ensure the mounting are secure.

Repeat the procedure at HIGH range setting.

CAUTION:NEVER attempt to change from HIGH to LOW range with the machine running.

2. STARTING UNDER NORMAL CONDITIONS

- 1) Take all necessary precautions previously stated,and ensure the workpiece is fixed firmly.
- 2) Set the Speed range control lever to HIGH or LOW as required.
- 3) Set the Motor power switch(E) to "I" position.
- 4) Proceed to start the machine as described in Section 1.Above.
- 5) If the machine is finished with or is to be left unattended,turn the Motor power switch(E) to "0" position then disconnect from the mains supply.

ATTENTION: The power supply system of this machine has an auto over-load protective function.If the feeding is too fast or drilling is too deep, the system will stop working,a yellow lamp(behind the fuselage) will light.Just turn off the Variable Speed control knob(D) and then turn on again.

The system will work again and the yellow lamp will off automatically.

8-2 *Electrical Circuit Diagram*

1. Electrical Circuit Diagram

220V~240V

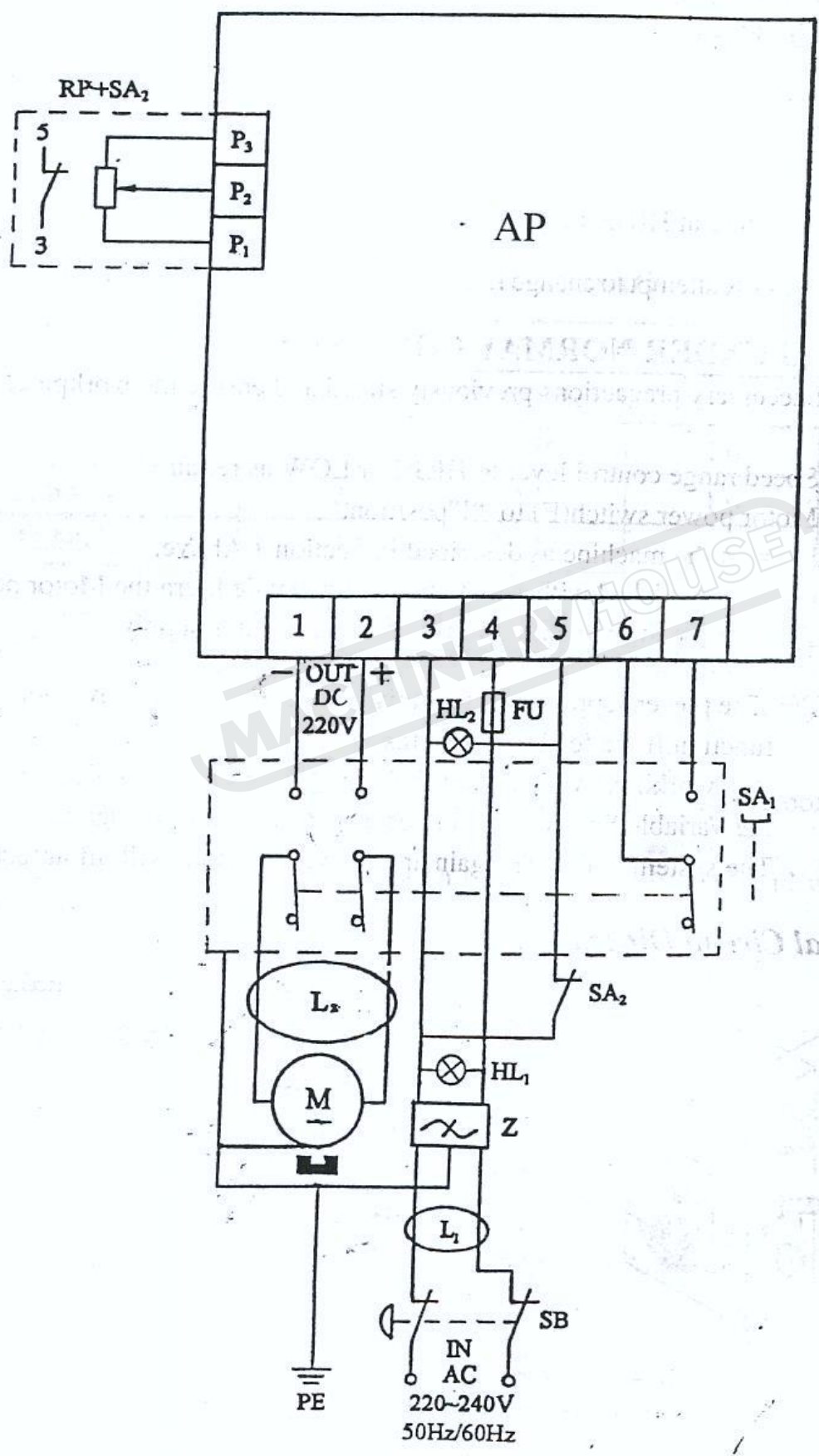

2. Electrical Circuit Diagram

105V~115V

